

Fluid control equipments

No. 77/500, T.N.C.C Building, Annasalai,
Teynampet, Chennai - 600 006.

Telefax: +91-44-24481130
E-mail : flu_con@vsnl.com
Website: www.flu-con.com

POLYPROPYLENE “MAXIMIZER”

FILTER PRESS (Series-200)

We are leading manufacturers of pressure filtration equipments in Tamilnadu for over 20 years. The Maximizer series filter presses are best suited for chemical and process industries and for effluent and sewage treatment plants handling flow rates of 500 to 1500 KLD of slurry per day. We have supplied more than 100 presses to various clients all over India, with various stages of automation. We custom build filter presses according to customer needs after conducting pilot studies.

FILTER PRESS : WHAT IS IT?

Filter press is a device which is used for separating suspended solids from the liquids. In the recessed type, the slurry is fed through the central inlet and the solids are retained in the recess between the plates, while the filtrate is collected through the corners.



SOME OF OUR DISTINGUISHED CLIENTS

FOOD AND BEVERAGES

INDO NISSION FOODS LTD
MEGA TRENDS INC (TORINO)
KALIMARK BEVERAGES LTD

EFFLUENT AND SEWAGE TREATMENT CONSULTANTS

AQUA DESIGN INDIA LTD
LIVING WATERFINE TECHNOLOGIES PVT LTD
QUALITY WATER MANAGEMENT SYSTEMS PVT LTD

HERBAL AND BIOTECHNOLOGY

KOTHARIPHYTO CHEMICALS INTERNATIONAL
MALLADI DRUGS AND PHARMACEUTICALS
THANGAM EXTRACTS

BATTERIES

INDO NATIONAL GROUP (NIPPO BATTERIES)
AMARA RAJA INDUSTRIES LTD (AMARON BATTERIES)
TAFE POWER SOURCE DIVISION

TEXTILES AND LEATHERS

BASIC CHEMICALS & INTERMEDIATES
TEXTAN CHEMICALS PVT LTD
RISHAB INTERMEDIATES

CHEMICAL INDUSTRIES

CHEMPLAST SANNAR PVT LTD
SOUTHERN CHEMICALS PVT LTD
AAR VEE CHEM

RUBBER AND LATEX PROCESSING

COMFOAMS LTD
MARDEC LATEX PVT LTD
R.K. LATEX PVT LTD

GOVT. INDUSTRIES AND LABS

CENTRAL LEATHER RESEARCH INSTITUTES
INDIAN INSTITUTE OF TECHNOLOGY, MADRAS
MURHOPYE SCIENTIFIC

SPECIFICATION

FILTRATION AREA AND CAKE HOLDING VOLUME CHART FOR RECESSED & PLATE AND FRAME FILTER PRESSES

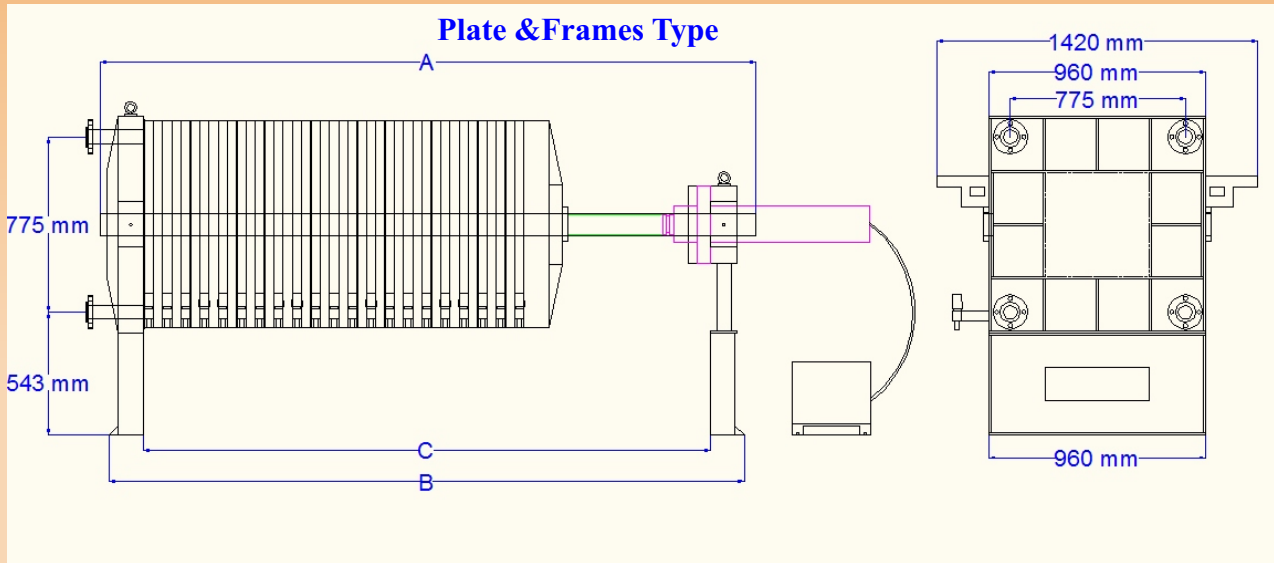

Size	No. of Frames	Thick in mm.	Cake Vol. In Liters	Area in Sq.m.	Dimension in mm		
					A	B	C
915 mm (36")	20	50	672.41	26.90	3500	3420	3120
	24	50	806.87	32.28	3900	3820	3520
	30	50	1088.62	40.34	4500	4420	4120
	35	50	1143.13	45.72	4850	4770	4470
	40	50	1344.81	53.79	5450	5370	5070

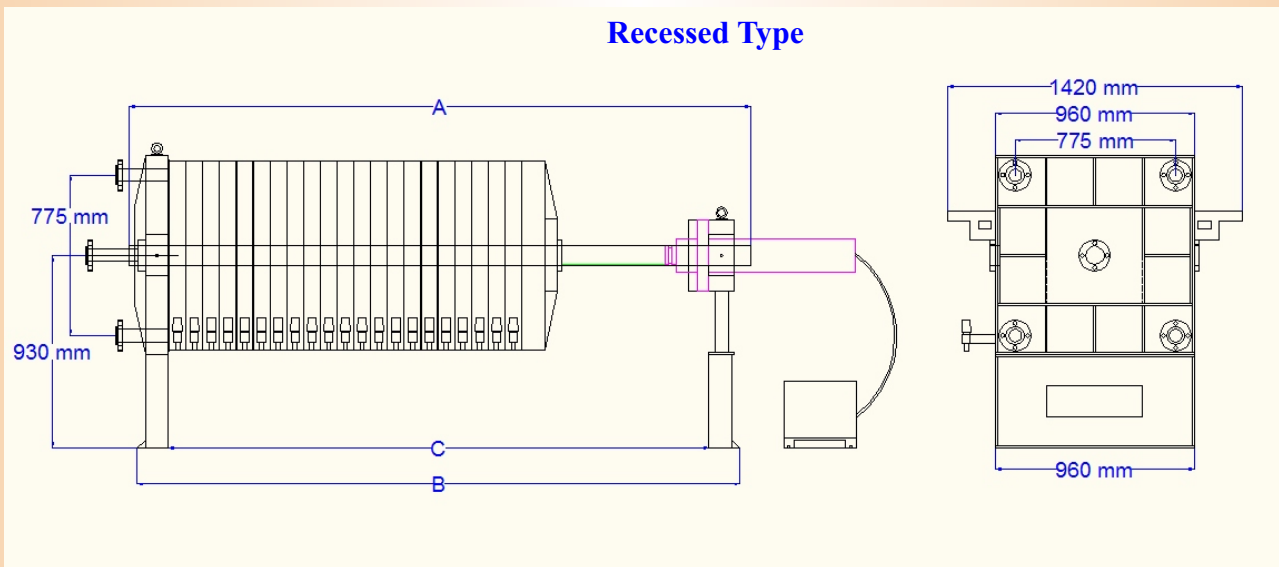

Size	No. of Frames	Thick in mm.	Cake Vol. In Liters	Area in Sq.m.	Dimension in mm		
					A	B	C
915 mm (36")	20	50	672.41	26.90	3000	2920	2620
	24	50	806.87	32.28	3350	3270	2970
	30	50	1088.62	40.34	3800	3720	3410
	35	50	1143.13	45.72	4150	4070	3770
	40	50	1344.81	53.79	4600	4520	4220

All Dimensions are approximate confirm with us for exact details

* For Manual closing A,B,C will be approximate 250mm less

** For Motor Hydraulic closing A,B,C will be approximate 100mm less